

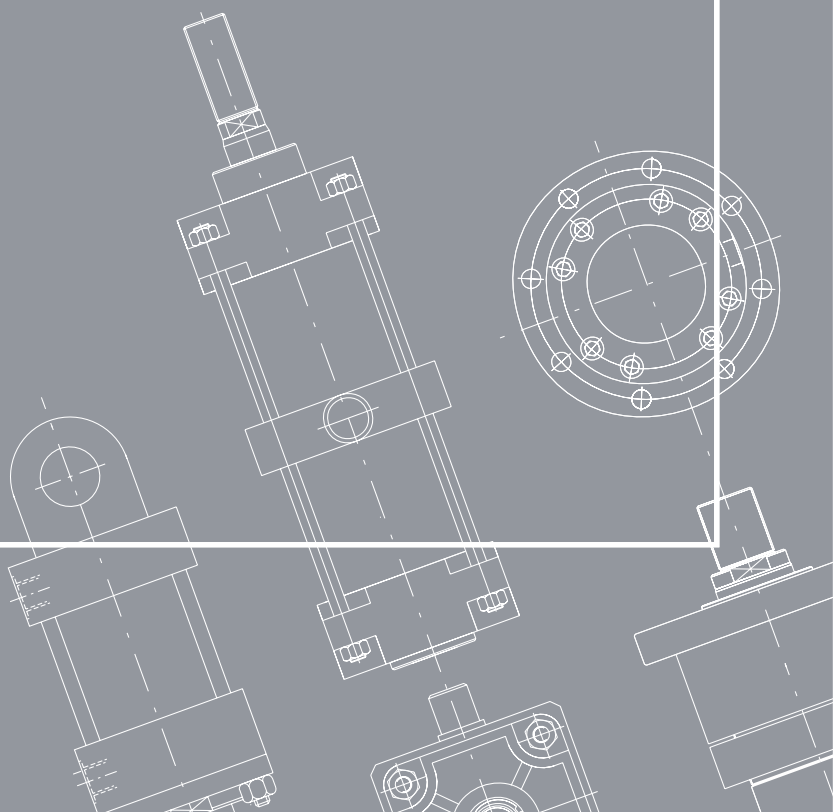

CILINDRI PNEUMATICI
C . N . O . M . O .

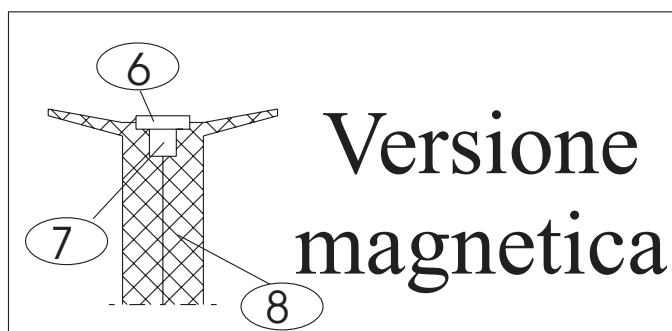

Ricambi

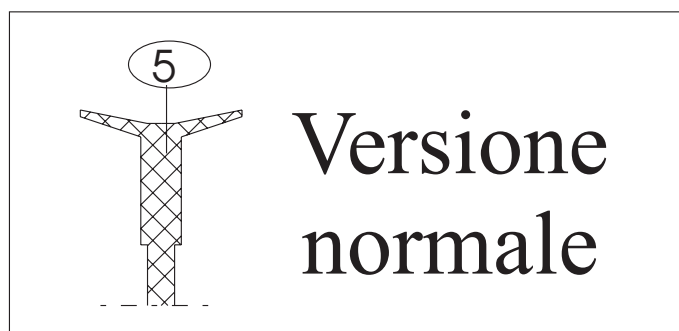
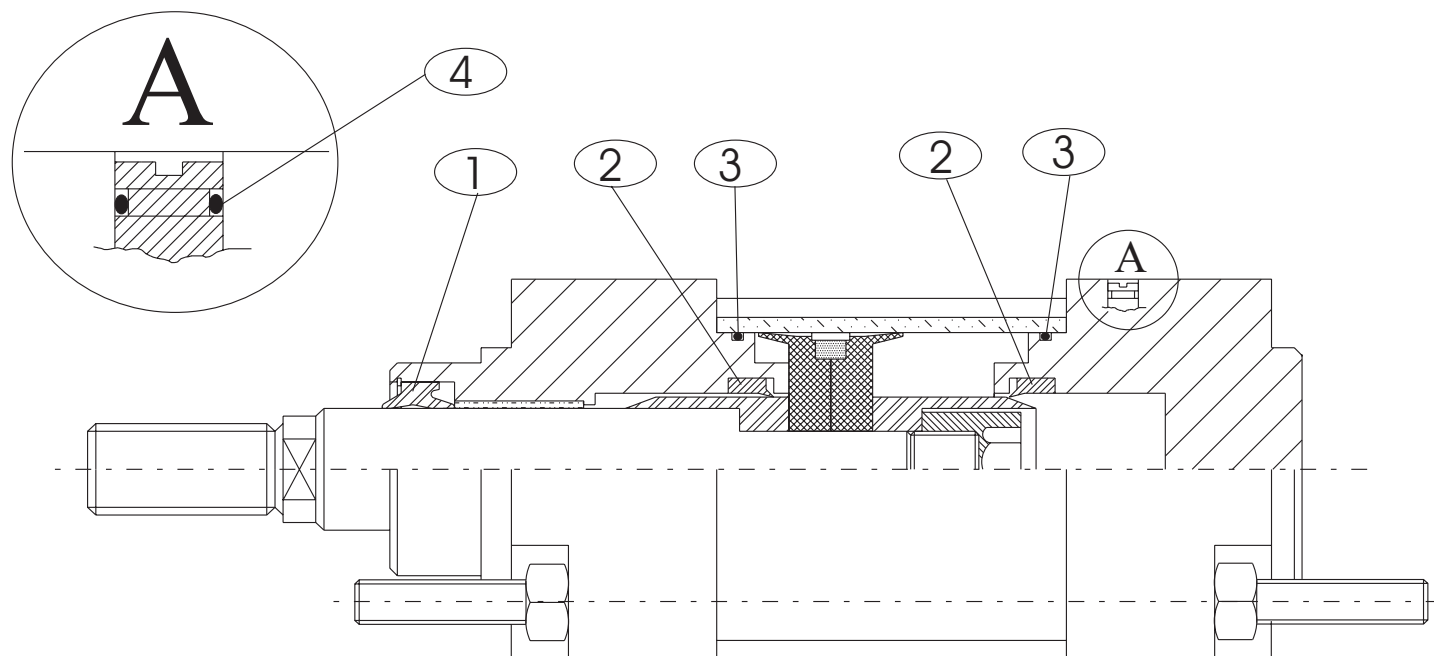

<i>Pos.</i>	<i>Descrizione</i>	<i>Materiale</i>	<i>Q.tà</i>
1	Guarnizione stelo	Gomma nitrilica	1
2	Guarnizione ammortizzo	Gomma nitrilica	2
3	Guarnizione testate	Gomma nitrilica	2
4	Guarnizione spillo	Gomma nitrilica	2
5	Guarnizione pistone	Gomma nitrilica	1
6	Anello di guida	Resina acetlica	1
7	Inserto magnetico	Plastoferrite	1
8	Guarnizione pistone	Gomma nitrilica	1

		<i>C.N.O.M.O normale</i>	<i>C.N.O.M.O magnetico</i>
Caratteristiche costruttive	<i>Stelo</i>	Acciaio C40 bonificato e cromato a richiesta: INOX AISI 304 rettificato	Acciaio C40 bonificato e cromato a richiesta: INOX AISI 304 rettificato
	<i>Camicia</i>	Acciaio verniciato a richiesta: Ottone-Alluminio-Acciaio Crom.	Alluminio anodizzato duro a richiesta: Ottone
	<i>Tiranti</i>	Acciaio nichelato a richiesta: INOX AISI 304	Acciaio INOX AISI 304
	<i>Testate</i>	Alluminio pressofuso	Alluminio pressofuso
	<i>Bronzina</i>	Autolubrificante in bronzo sinterizzato	Autolubrificante in bronzo sinterizzato
	<i>Pistone</i>	Gomma NBR con inserto metallico a richiesta: VITON con inserto metallico	Lega leggera con inserto in plastoferrite rivestita con gomma NBR
	<i>Guarnizioni</i>	Gomma NBR atte a funz. anche a secco a richiesta: VITON	Gomma NBR atte a funz. anche a secco a richiesta: VITON (tranne il pistone)

Dati tecnici	<i>Pressione di esercizio</i>	Min. 1 Kg/cm ² - max 10 Kg/cm ²
	<i>Temp. di lavoro</i>	NBR -25°C/+80°C VITON -25°C/+140°C
	<i>Fluido</i>	Aria compressa preferibilmente lubrificata
	<i>Velocità max.</i>	1000 mm/sec
	<i>Ammortizzazione</i>	Regolabile progressivamente mediante apposita vite
	<i>Lunghezza con ammortizzatore</i>	Ales. 32 40 50 63 80 100 125 160 200 250 320 400 Lung. 20 20 20 25 25 25 25 35 35 40 40 40

Forze teoriche

Ales.		1Kg/cm ²	2Kg/cm ²	3Kg/cm ²	4Kg/cm ²	5Kg/cm ²	6Kg/cm ²	7Kg/cm ²	8Kg/cm ²	9Kg/cm ²	10Kg/cm ²
32	Spinta	8	16	24	32	40	48	56	64	72	80
	Tiro	7	14	21	28	35	41	48	55	62	69
40	Spinta	13	25	37	50	63	75	87	100	112	125
	Tiro	10	20	30	40	50	60	70	80	90	100
50	Spinta	20	39	59	78	98	117	137	156	176	196
	Tiro	17	34	51	68	85	102	119	136	153	170
63	Spinta	31	62	93	124	155	186	217	248	279	311
	Tiro	27	55	82	109	136	163	191	218	245	273
80	Spinta	50	100	151	200	251	301	351	401	451	502
	Tiro	46	93	139	186	232	278	324	371	417	464
100	Spinta	78	157	236	314	392	471	549	628	706	785
	Tiro	71	143	214	285	357	428	499	571	642	714
125	Spinta	123	245	368	490	613	735	858	980	1103	1226
	Tiro	116	231	346	462	577	693	808	924	1039	1155
160	Spinta	201	402	602	804	1004	1205	1406	1607	1808	2009
	Tiro	188	377	565	753	942	1130	1319	1507	1695	1884
200	Spinta	314	628	942	1256	1570	1884	2198	2512	2826	3140
	Tiro	301	603	904	1205	1507	1808	2109	2411	2712	3014
250	Spinta	490	981	1472	1962	2453	2943	3434	3924	4415	4906
	Tiro	471	942	1413	1884	2355	2826	3297	3768	4238	4710
320	Spinta	804	1607	2411	3215	4020	4823	5627	6430	7235	8040
	Tiro	691	1381	2072	2763	3454	4145	4835	5526	6217	6910
400	Spinta	1256	2512	3768	5024	6280	7536	8792	10048	11304	12560
	Tiro	1143	2286	3429	4572	5712	6858	8001	9144	10287	11430

Codici ordinazione cilindri pneumatici:

DC 000 B 3 Z N 0000 / O

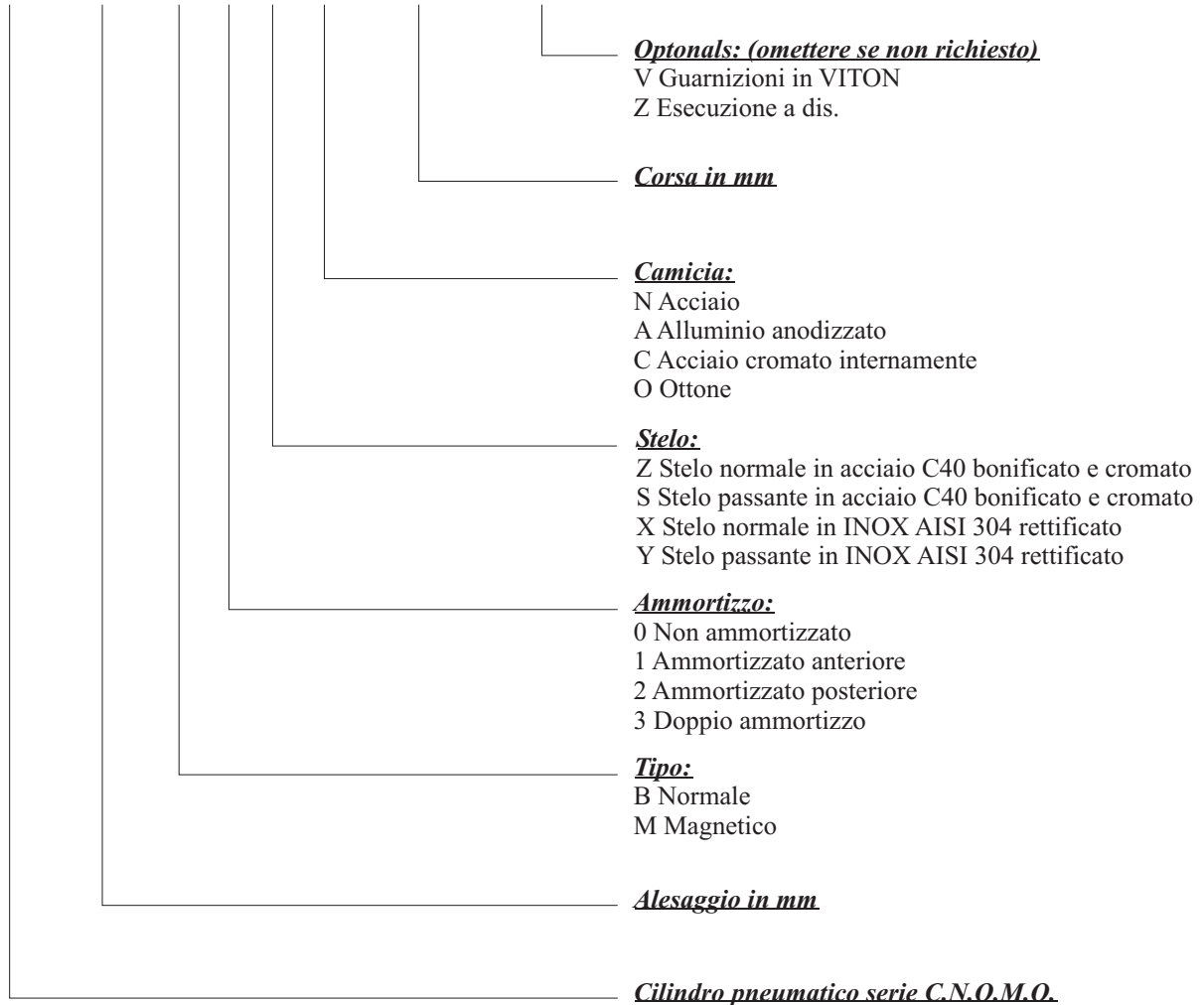

Codici ordinazione ricambi:

KDC 000 B / O

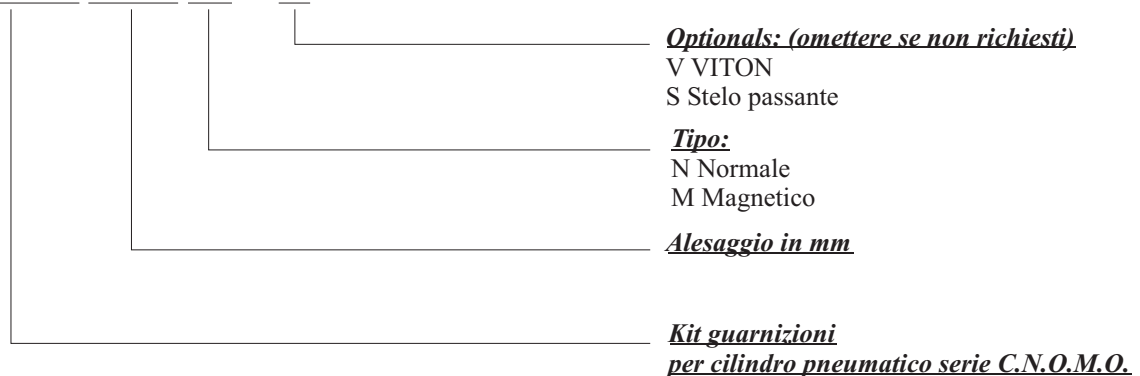

Versione base

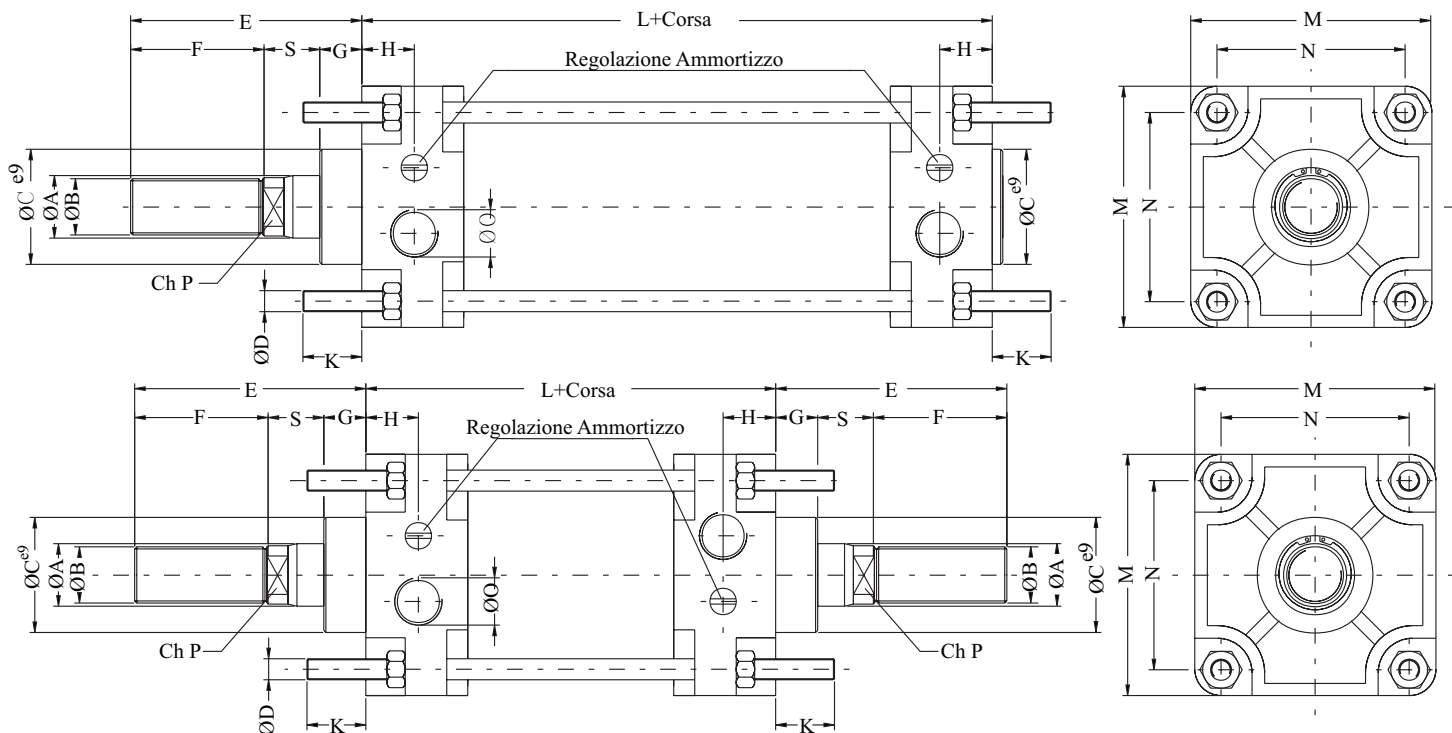

Ales.	A	B	C	D	E	F	G	K	S	M	N	O		P	H	L	
												Fil.	Foro			Norm.	Magn.
32	12	M10x1.5	25	M6	45	20	15	17	10	45	33	1/8"	5	8	17	80	87*
40	18	M16x1.5	32	M6	70	36	15	17	19	52	40	1/4"	8	13	23	110	116*
50	18	M16x1.5	32	M8	70	36	15	23	19	65	49	1/4"	8	13	25	110	114*
63	22	M20x1.5	45	M8	85	46	20	23	19	75	59	3/8"	12	17	26	125	130*
80	22	M20x1.5	45	M10	85	46	20	28	19	95	75	3/8"	12	17	24	125	130*
100	30	M27x2	55	M10	110	63	20	28	27	115	90	1/2"	15	24	31.5	145	149*
125	30	M27x2	55	M12	110	63	20	34	27	140	110	1/2"	15	24	30.5	145	148*
160	40	M36x2	65	M16	135	85	25	42	25	180	140	3/4"	20	32	33	180	180
200	40	M36x2	65	M16	135	85	25	42	25	220	175	3/4"	20	32	33	180	180
250	50	M36x2	90	M20	165	85	50	50	30	280	220	3/4"	20	41	35	230	---
320	60	M36x2	115	M24	195	90	60	60	45	360	280	1"	20	46	40	280	---
400	60	M36x2	115	M24	195	90	60	60	45	450	350	1"	20	46	40	280	---

* Non a norme C.N.O.M.O.

Fissaggio a flangia (060704)

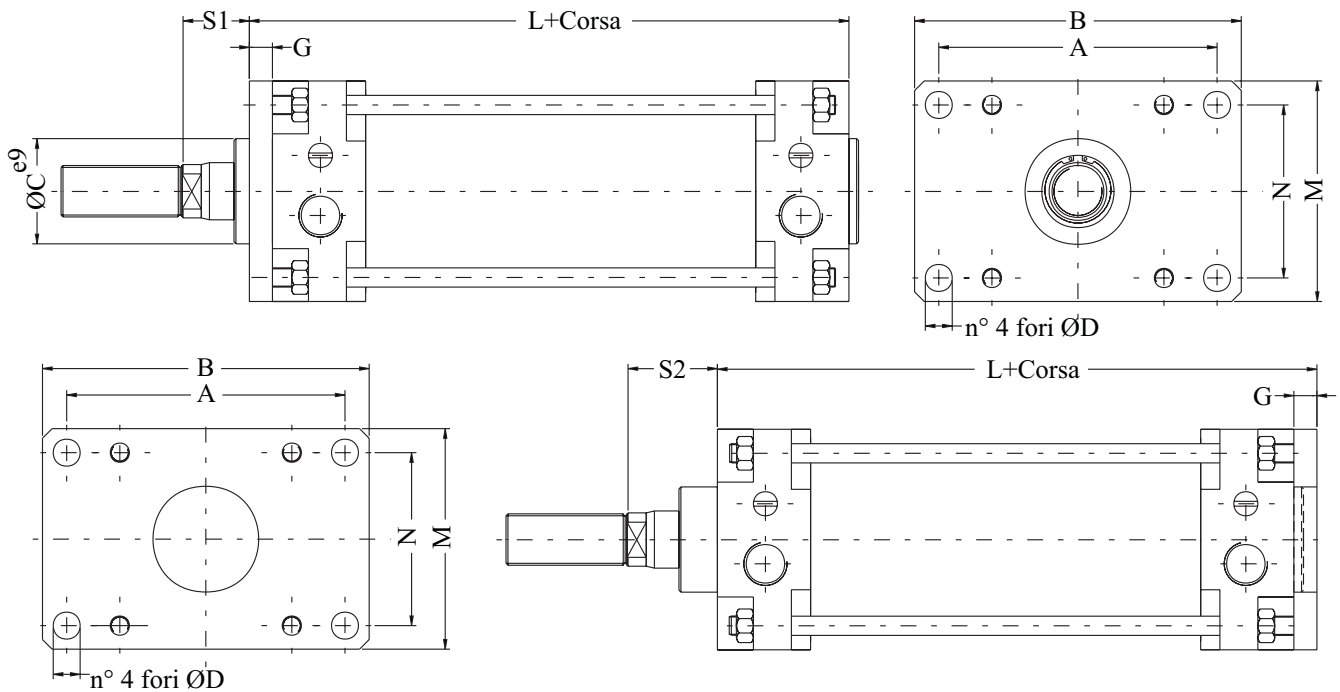

Ales.	A	B	C	D	G	M	N	S1	S2	L		Cod. Ant.	Cod. Post.
										Norm.	Magn.		
32	68	80	25	9	8	45	33	17	25	88	95*	XFA 032	XFP 032
40	78	90	32	9	8	52	40	26	34	118	124*	XFA 040	XFP 040
50	94	110	32	11	10	65	49	24	34	120	124*	XFA 050	XFP 050
63	104	120	45	11	10	75	59	29	39	135	140*	XFA 063	XFP 063
80	130	150	45	14	12	95	75	27	39	137	142*	XFA 080	XFP 080
100	150	170	55	14	12	115	90	35	47	157	161*	XFA 100	XFP 100
125	180	205	55	18	16	140	110	31	47	161	164*	XFA 125	XFP 125
160	228	260	65	22	20	180	140	30	50	200	200	XFA 160	XFP 160
200	268	300	65	22	20	220	175	30	50	200	200	XFA 200	XFP 200

* Non a norme C.N.O.M.O.

Fissaggio a cerniera (060709)

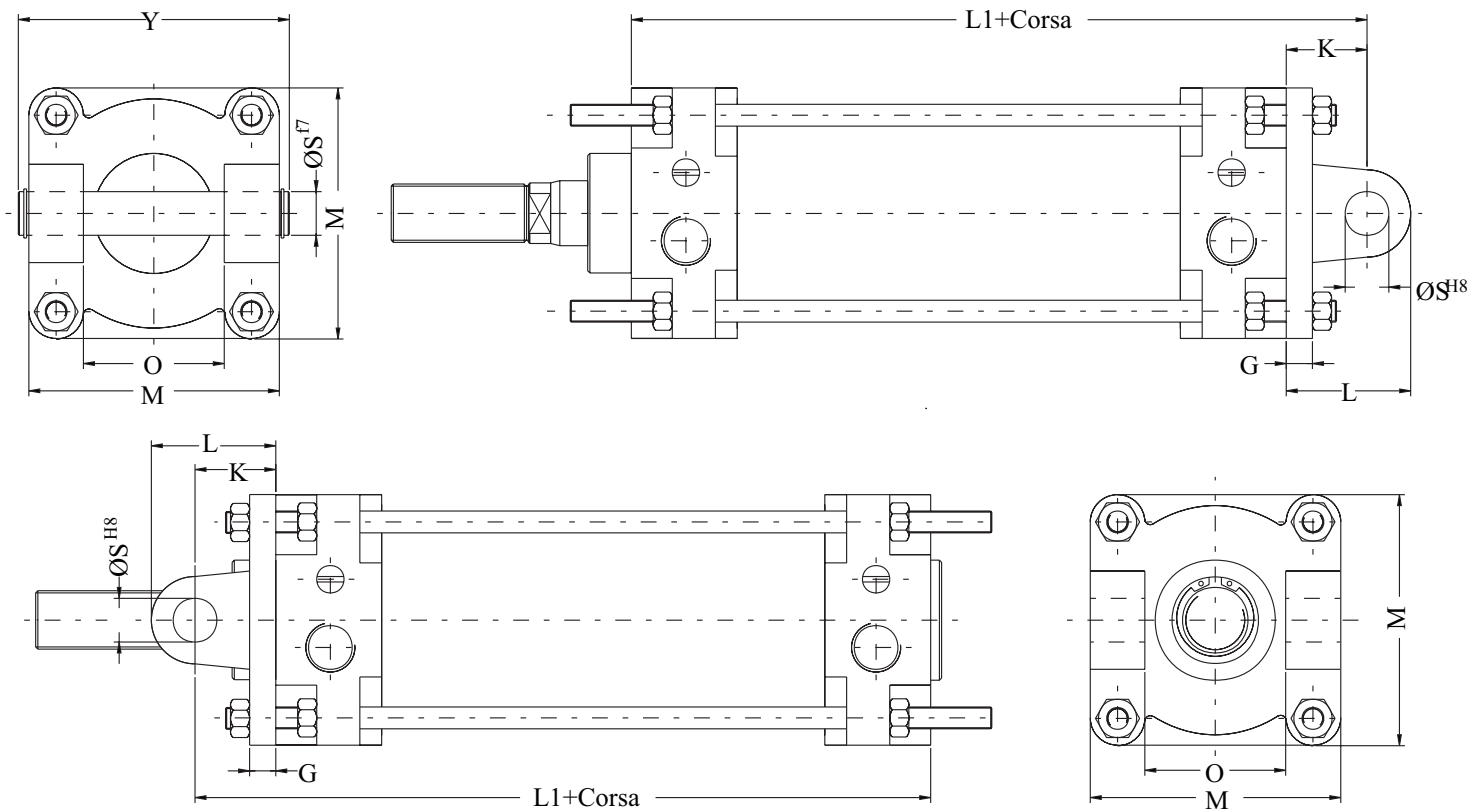

Ales.	G	K	L	M	O	S	Y	L1		Cod.
								Norm.	Magn.	
32	8	18	29	45	26	8	52	98	105*	XCF 032
40	8	24	35	52	33	12	64	134	140*	XCF 040
50	10	26	39	65	33	12	74	136	140*	XCF 050
63	10	30	47	75	47	16	85	155	160*	XCF 063
80	12	32	49	95	47	16	105	157	162*	XCF 080
100	12	37	58	115	57	20	125	182	186*	XCF 100
125	16	41	70	140	57	20	150	186	189*	XCF 125
160	20	55	85	180	72	25	192	235	235	XCF 160
200	20	55	85	220	72	25	232	235	235	XCF 200
250	25	70	110	270	110	40	210	300	---	XCF 250

* Non a norme C.N.O.M.O.

Fissaggio a piedini (060707)

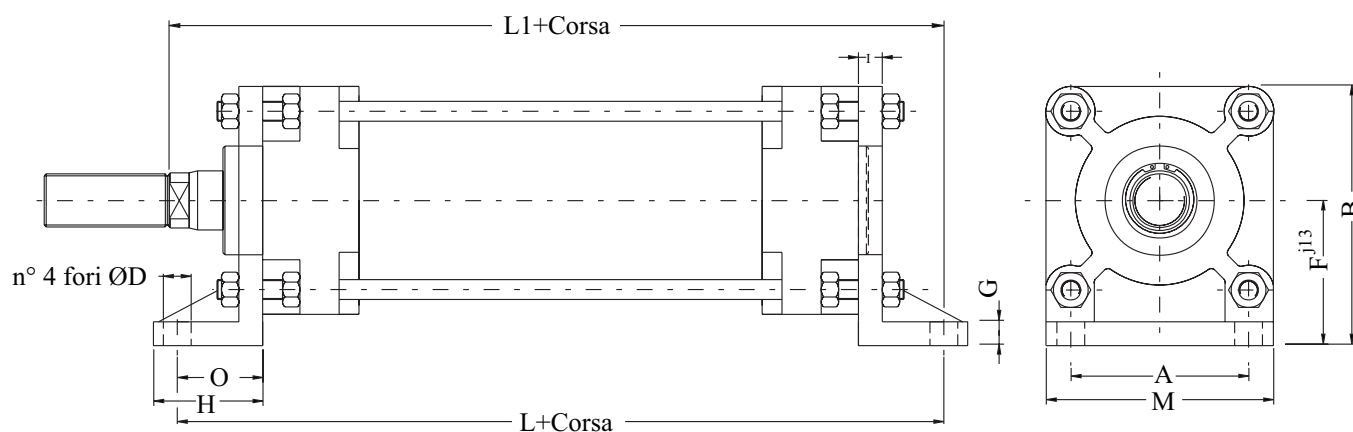

Ales.	A	B	D	F	G	H	I	M	O	L		LI		Codice Articolo
										Normale	Magnetico	Normale	Magnetico	
32	28	54.5	9	32	8	35	8	45	27	134	141*	132	139*	XP 032
40	36	62	9	36	8	35	8	52	27	164	170*	171	177*	XP 040
50	45	77.5	11	45	10	43	8	65	35	180	184*	179	183*	XP 050
63	55	87.5	11	50	10	45	10	75	35	195	200*	199	204*	XP 063
80	70	110.5	14	63	12	55	12	95	43	211	216*	207	212*	XP 080
100	90	130.5	14	73	12	55	12	115	43	231	235*	235	239*	XP 100
125	100	161	18	91	16	68	16	140	52	249	252*	244	247*	XP 125
160	130	205	22	115	20	80	20	180	62	304	304	292	292	XP 160
200	170	245	22	135	20	90	20	220	62	304	304	292	292	XP 200

* Non a norme C.N.O.M.O.

Fissaggio a snodo mediano (060712)

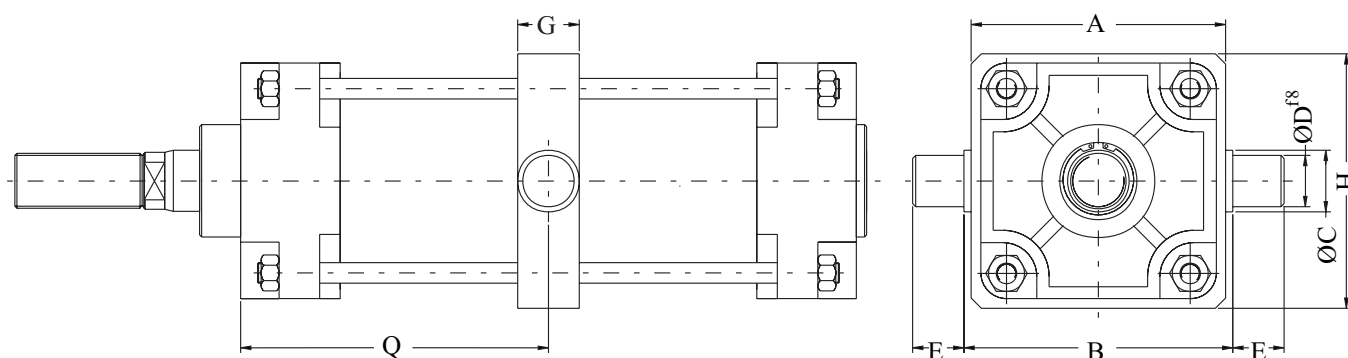

<i>Ales.</i>	<i>A</i>	<i>B</i>	<i>C</i>	<i>D</i>	<i>E</i>	<i>G</i>	<i>H</i>	<i>Q_{min}</i>	<i>Cod.</i>
32	46	50	15	12	12	20	46	36	XSM 032
40	58	63	20	16	16	20	58	46	XSM 040
50	68	73	20	16	16	20	68	46	XSM 050
63	84	90	25	20	20	30	84	58	XSM 063
80	102	108	25	20	20	30	102	55	XSM 080
100	124	131	30	25	25	30	124	65	XSM 100
125	152	159	30	25	25	30	152	62	XSM 125
160	190	198	40	32	32	40	190	80	XSM160
200	240	248	40	32	32	40	240	80	XSM 200

Forcella (060714)

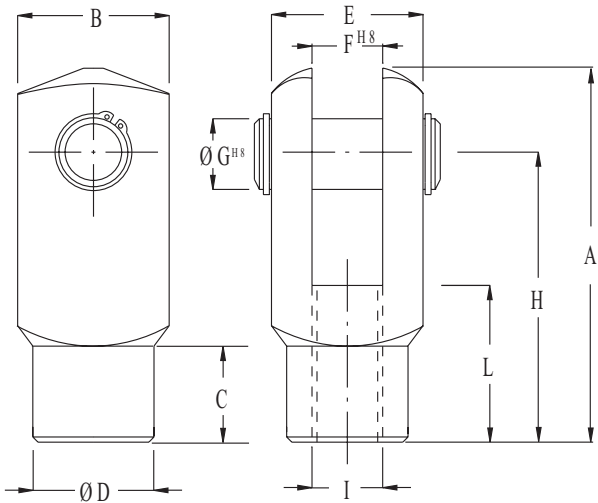

Ales.	<i>I</i>	<i>A</i>	<i>B</i>	<i>C</i>	<i>D</i>	<i>E</i>	<i>F</i>	<i>G</i>	<i>H</i>	<i>L</i>	Cod.
32	M10x1.5	45	22	14	18	22	11	8	36	20	XFS 032
40	M16x1.5	64	26	17	26	36	18	12	51	26	XFS 040
50	M16x1.5	64	26	17	26	36	18	12	51	26	XFS 040
63	M20x1.5	80	34	18.5	34	45	22	16	63	30	XFS 063
80	M20x1.5	80	34	18.5	34	45	22	16	63	30	XFS 063
100	M27x2	105	42	30	42	63	30	20	85	45	XFS 100
125	M27x2	105	42	30	42	63	30	20	85	45	XFS 100
160	M36x2	140	50	45	50	80	40	25	115	75	XFS 160
200	M36x2	140	50	45	50	80	40	25	115	75	XFS 160

Testa a snodo

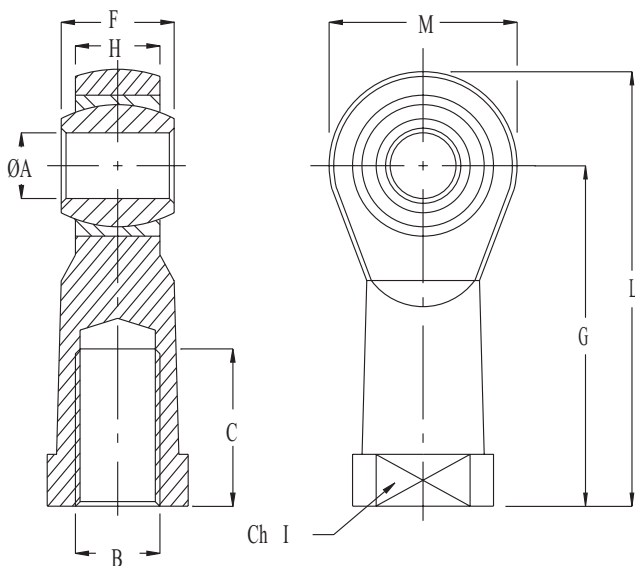

Ales.	<i>B</i>	<i>A</i>	<i>C</i>	<i>F</i>	<i>G</i>	<i>H</i>	<i>I</i>	<i>L</i>	<i>M</i>	Cod.
32	---	---	---	---	---	---	---	---	---	XFM 032
40	M16x1.5	16	28	21	64	15	22	85	42	XFM 040
50	M16x1.5	16	28	21	64	15	22	85	42	XFM 040
63	M20x1.5	20	33	25	77	18	30	102	50	XFM 063
80	M20x1.5	20	33	25	77	18	30	102	50	XFM 063
100	M27x2	30	51	37	110	25	41	145	70	XFM 100
125	M27x2	30	51	37	110	25	41	145	70	XFM 100
160	M36x2	35	56	43	125	28	50	165	80	XFM 160
200	M36x2	35	56	43	125	28	50	165	80	XFM 160

Fissaggio a controcerniera diritta (060710)

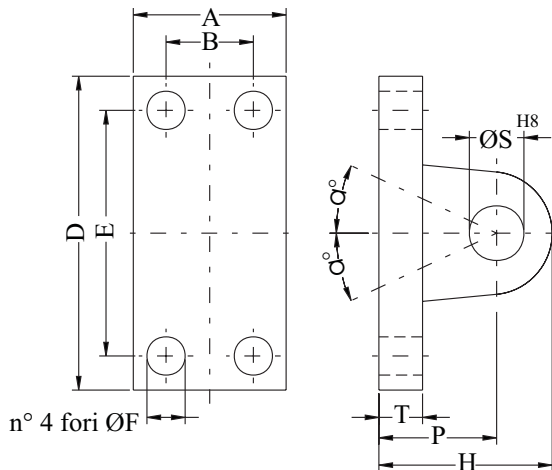

Ales.	A	B	D	E	F	H	P	S	T	α	Cod.
32	25	---	40	28	7	28	18	8	8	30	XCD 032
40	32	16	52	38	9	38	26	12	10	25	XCD 040
50	32	16	52	38	9	38	26	12	10	30	XCD 040
63	46	25	75	54	11	50	34	16	12	30	XCD 063
80	46	25	75	54	11	50	34	16	12	30	XCD 063
100	56	32	115	90	14	63.5	41	20	16	30	XCD 100
125	56	32	115	90	14	63.5	41	20	16	30	XCD 100
160	71	43	180	150	18	80	55	25	20	30	XCD 160
200	71	43	180	150	18	80	55	25	20	30	XCD 160

Fissaggio a controcerniera angolare (060711)

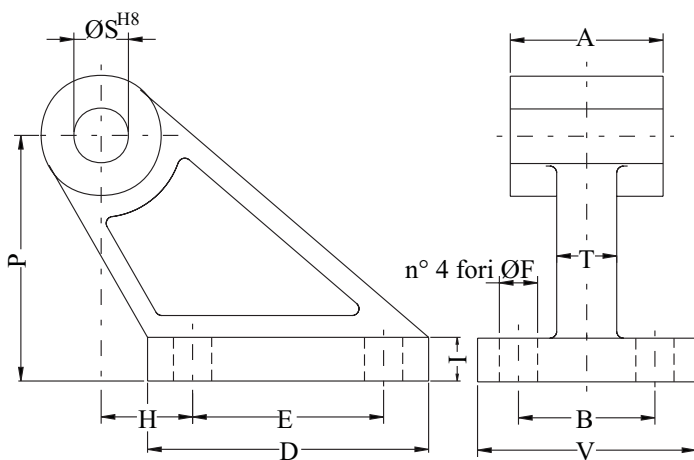

Ales.	A	B	D	E	F	H	I	P	S	T	V	Cod.
32	25	25	37	20	7	18	8	32	8	10	41	XCA 032
40	32	32	54	32	9	25	10	45	12	12	52	XCA 040
50	32	32	54	32	9	25	10	45	12	12	52	XCA 040
63	46	40	75	50	11	32	12	63	16	15	63	XCA 063
80	46	40	75	50	11	32	12	63	16	15	63	XCA 080
100	56	50	103	70	14	40	16	90	20	22	80	XCA 100
125	56	50	103	70	14	40	16	90	20	22	80	XCA 100
160	71	63	154	110	18	50	20	140	25	25	110	XCA 160
200	71	63	154	110	18	50	20	140	25	25	110	XCA 160

Sensori magnetici di prossimità

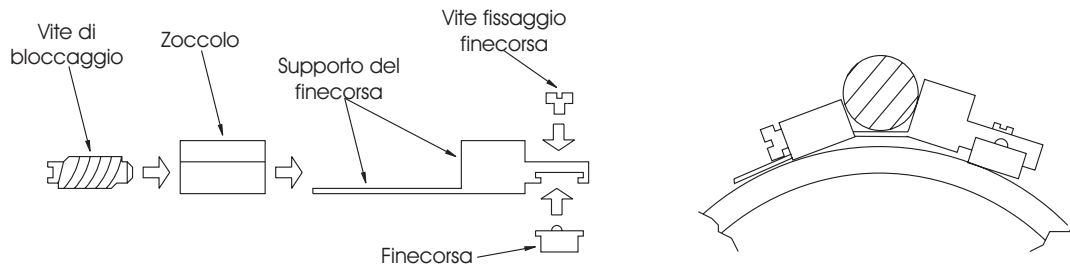

<i>Dati tecnici</i>	<i>MA3GA3</i>	<i>MA3GA4</i>	<i>MA3GA5</i>
Contatto	NA reed	NA elettronico (Hall)	NA elettronico (Hall)
Corrente I _{max} (mA)	1000	300	300
Tensione V _{min} (V)	2.5	10	10
Tensione V _{max} (V)	250	30	30
Potenza max (W/VA)	50/50	---	---
Collegamento	2 fili	3 fili PNP	3 fili NPN
Connessione	connettore	cavo dir.	cavo dir.
LED	rosso	rosso	rosso
Materiale cavo	PVC	PVC	PVC
Sez. cond. (mm ²)	0.34	0.14	0.14

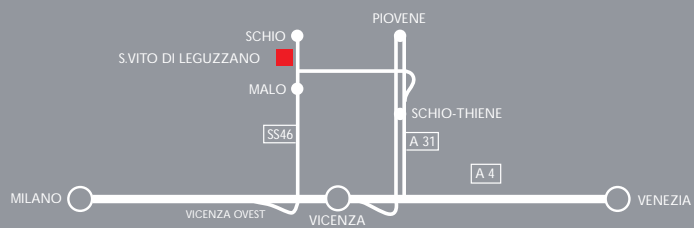

CMB S.r.l. - Via Vicenza, 17
36030 S.Vito di Leguzzano (VI) Italy
Tel +39 0445 519555 r.a.
Fax +39 0445 519481
www.cmbcilindri.com
info@cmb-cil.com